



Description

Industry 4.0 (4th industrial revolution) corresponds to a new way of organizing the means of production, thanks to innovations linked to the Internet of Things and digital technologies. The companies Didalab and Créa Technologie propose you a homothetic system of a recycling line of metallic parts.

A conveyor is fed with different boxes. At the beginning of the conveyor, a presence/box size sensor (and then an inductive sensor as an optional extra) is used to characterize the boxes. The parts identified as too small for recycling and/or non-metallic are then conveyed to the end of the line to be sent to the wastebin. The boxes, identified as parts to be recycled are then removed from the conveyor using a mechanical arm and placed in a sorting bin.

Despite its small size (it can be placed on a table), SA-TRI-BOX 4.0 uses many technologies (industrial drives for SELV DC motors and brushless, sensors, automation). Moreover, according to the targeted teaching level, the scenarios/experiments proposed can go from the simple parameter setting of the various components to the complete development of the sorting chain (management of the axes, speed and position control ...). All sensor and actuator information are accessible via 4-mm safety sockets on the front panel, giving the possibility to freely connect the components to and from the PLC.

To best meet the new requirements of Industry 4.0, all sensor and actuator information is accessible via a web interface, allowing remote supervision and control of the sorting line.

Operating Part

1 DC motor with incremental encoder 500 pts/rev

Electro-magnet

1 Brushless motor with incremental encoder 12 pts/rev

Sensor

Conveyor

Recycling bins

1 Brushless motor with incremental encoder 500 pts/rev

Control Part

SIMATIC S7 1200 PLC

- 50 kB working memory, 6 fast counters and 2 integrated pulse outputs,
- Cycle time: 1ms for 1000 instructions,
- PROFINET port for programming.
- 1 single-user TIA Portal license

SIMATIC MICRO-DRIVE PDC100,

drive controller for servo control in the SELV range 24 to 48 VDC of the drive voltage supply max. 100W motor power, with STO hardwired

KTP 700 HMI (Optional extra)

- 7" graphic color operator panel KTP700
- WEB Server function allowing the connection of several PCs simultaneously

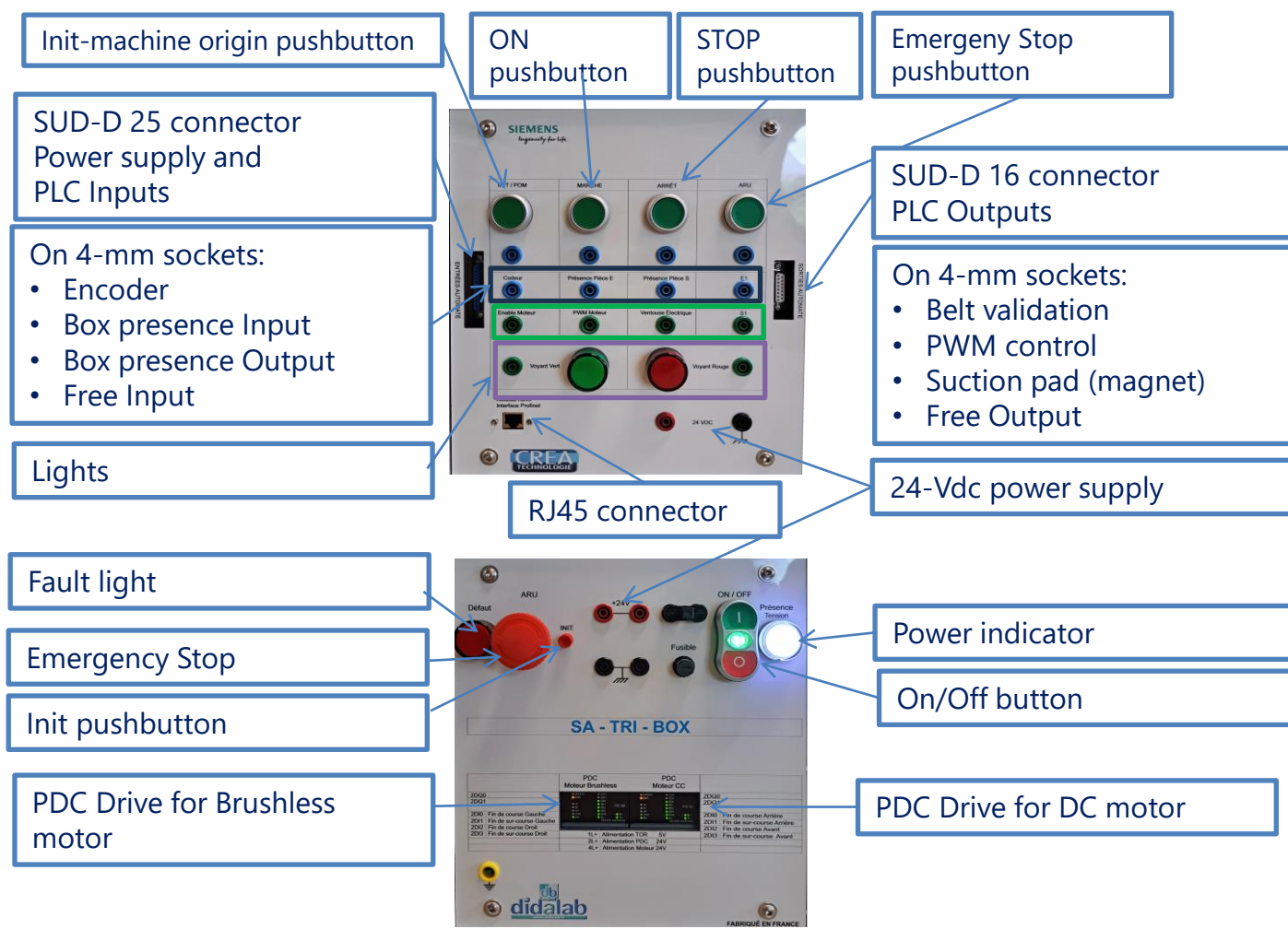

Schematic diagram

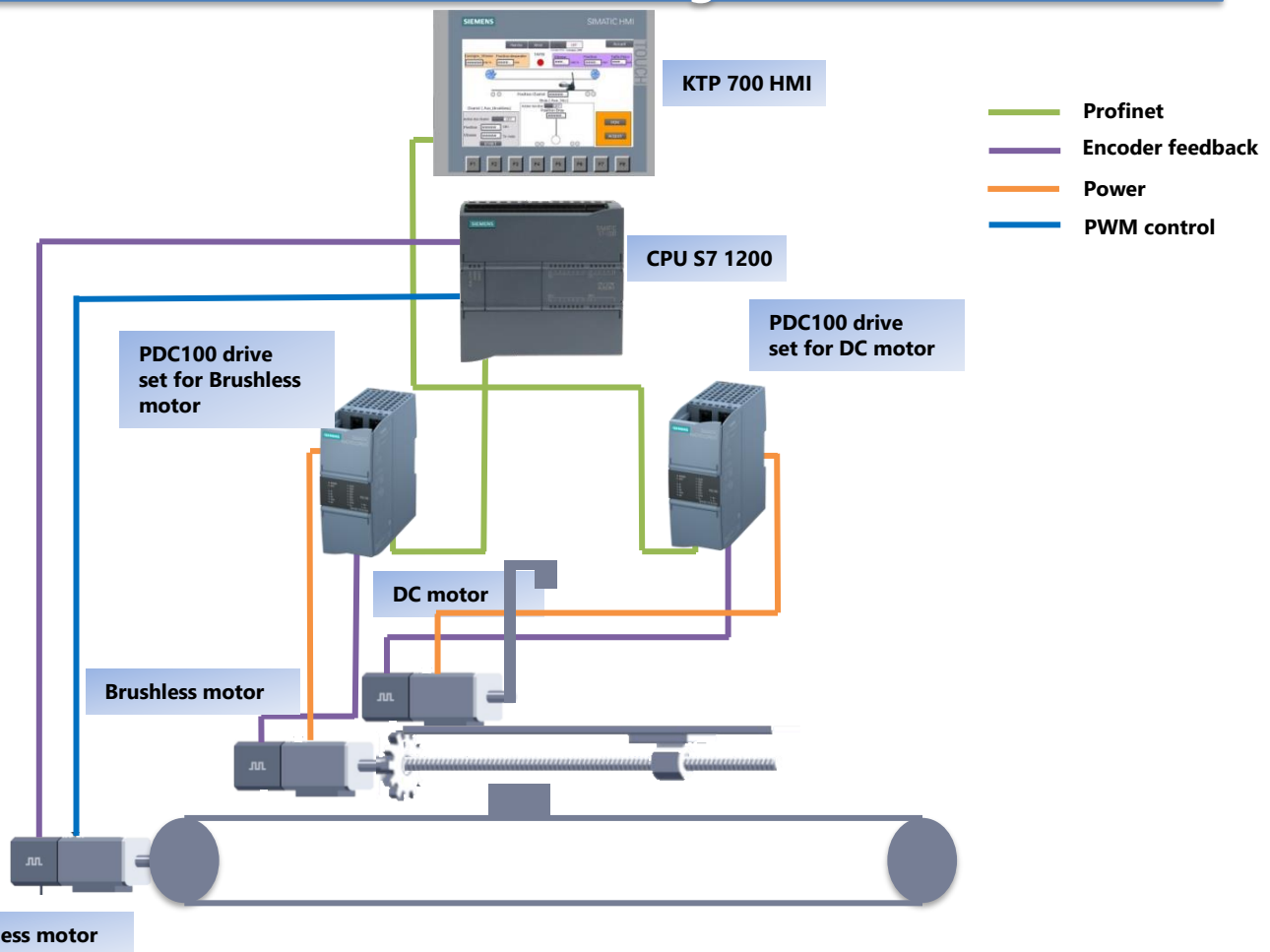

Experiments

- Exp1: Conveyor management
- Exp2: Learning of electric axis
- Exp3: Speed / position control
- Exp4: Implementation of a complete sorting line
- Exp5: HMI management
- Exp6: Supervision by Web server
- Exp7: Preventive maintenance: information feedback via MQTT protocol

Standard Configuration

ESD 600 B : SA-TRI-BOX 4.0		
Reference	Description	Qty
	OPERATING PART	
ESD600000	Aluminium profile system including: 1 meter long conveyor with its encoder motor. 1 box presence sensor 1 carriage with its brushless motor reducer 1 arm with mcc motor reducer and an electromagnet 2 recycling bins 1 waste bin 2 preset PDC100 drives (1 for DC motor, the other for Brushless motor) 1 switch	1
	CONTROL PART	
ESD003000	S7-1200 PLC, TIA Portal software included - 14 digital inputs 24 VDC, 10 outputs with status display, - 1 analog input 0/10 V, 1 output +/-10V 12 bits, - 1 simulator 8 miniswitches set on a trainer board with Ø 4 mm safety socket	1
ESD108000	HMI module KTP 700 with 4 RJ45 crossings and USB socket	Opt
	ACCESSORIES	
PEM080030	Set of 10 patching cords, 1 m, black, safety sockets Ø 4mm, stackable	1
PEM080031	Set of 10 patching cords, 1 m, red, safety sockets Ø 4mm, stackable	1
PEM080032	Set of 10 patching cords, 1 m, blue, safety sockets Ø 4mm, stackable	1

Trainings

- Vocational Training Centers
- Polytechnics
- Technical universities
- Engineer schools